

Product Data Sheet

603 GP XX Mod

Replace "XX" with 01 through 12 for number of poles

Terminal Block– Open Back
50 Amps, 600 Volts (AC/DC)



Insulator Strip Required for Voltage Rating

Copper Wire Only

Wire Range with Wire Binding Screw: #10 - #16 AWG
Wire Range with Listed Ring or Fork Lug: #6 – 16 AWG

11/16" Centers

Application torque: 20 in. lbs

Electrical Ratings:

- 50A with wire binding screw, (Based on NEC standards for 75°C ampacity)
- Wires larger than #10 AWG require Listed ring or fork lug, 600 Volts AC/DC (UL 1059 Class B, User Group – Commercial Appliances)
- Short Circuit Current Rating: 10,000A (Default)
- Approved for Factory and Field Wiring.

NOTE: Use outside these ratings must be judged in end-use application

Mechanical Ratings:

- Insulator base temperature rating: -40° C/F to 150°C (302°F) UL RTI
- Flammability rating of insulator base: UL 94V-0

Materials:

- Connector: Brass, nickel plated.
- Insulator base: Phenolic
- Screw, #10-32 Binder head, Phil-Slot: Steel, nickel plated
- Rivet: Brass, tin plated.

Agency Approvals:

- UL Recognized, UL 1059 Terminal Block Standard, File No. XCFR2.E47811
- CSA Certified, CSA C22.2 No. 158, File No. LR19766
- CE compliant, IEC 60947-7-1
- RoHS Compliant

Mounting:

Suggested product mounting hardware: #8 fastener, torque to 15in. lbs.

Accessories:

- JJ (GDI-30F) Material available. Glass-fiber filled, diallyl ortho-phthalate. UL-94 V0. Certifiable to Military Specifications MIL-M-14 and MIL-P-19833.

- Printing.

- Marking strips - sub mounted or top mounted. Can be made from XP (general purpose laminate), XXXPFR (flame retardant), GME (glass cloth melamine), or GEE (glass cloth epoxy) material.

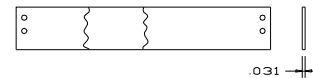

- Insulator strips - sub mounted, black only (BB) (Printing Unavailable). Insulator Strip will be the same width as the molding.

- Line to Line Jumper (J 603)



- Quick Connects

KT67



KT68



KT69



- Half Quick Connects

KT64



KT65



KT66



Tab width: 0.250
Tab thickness: 0.032

- Feed Thru Solder (Y)



- Phil-Slot Brass Screw (PSB)

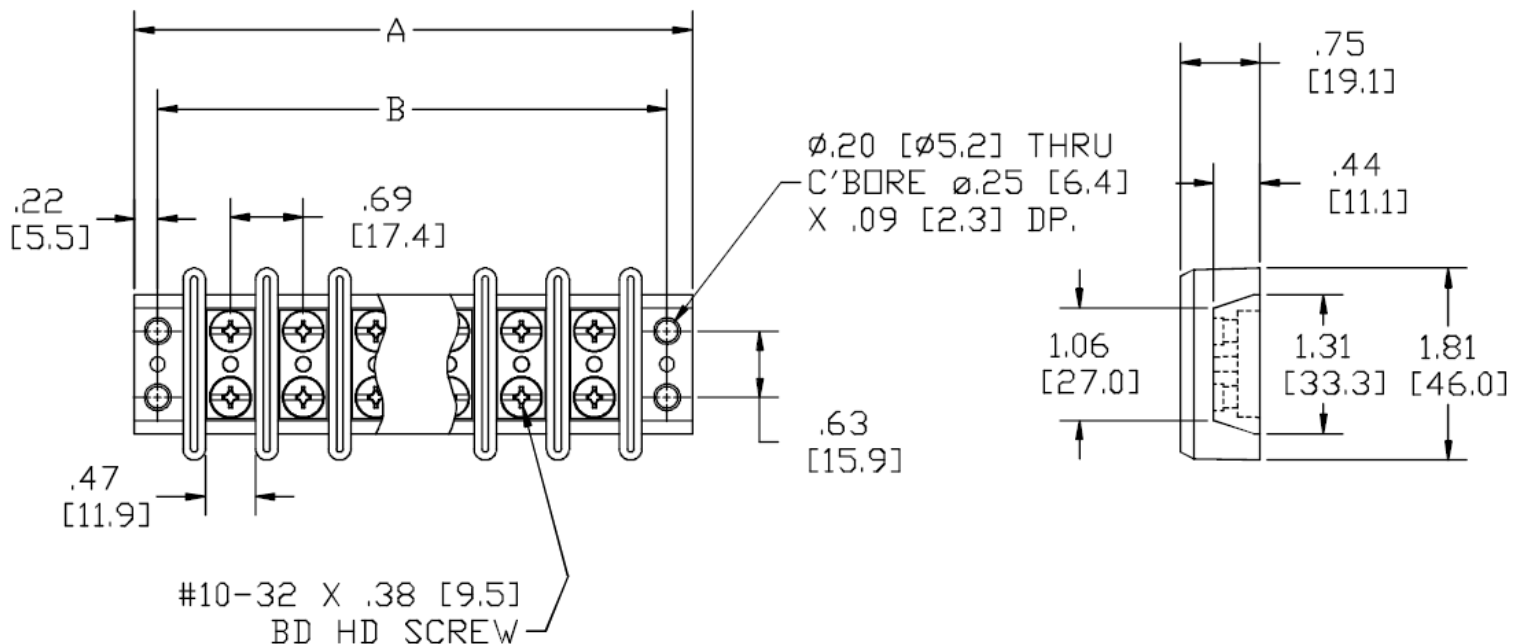

Dimensions

		A	B
603 GP 01	1	1.81	1.38
603 GP 02	2	2.50	2.06
603 GP 03	3	3.19	2.75
603 GP 04	4	3.88	3.44
603 GP 05	5	4.56	4.13
603 GP 06	6	5.25	4.81
603 GP 07	7	5.94	5.50
603 GP 08	8	6.62	6.19
603 GP 09	9	7.31	6.87
603 GP 10	10	8.00	7.56
603 GP 11	11	8.68	8.25
603 GP 12	12	9.37	8.94

MM = Dim X 25.4